

DIBD20, 40, 60 STYLE B CURTAIN TYPE DYNAMIC FIRE DAMPERS 1½ HOUR UL555 RATED FOR USE IN DYNAMIC AND STATIC SYSTEMS

APPLICATION

The Models DIBD20, 40 and 60 can be installed vertically in walls or horizontally in floors with fire resistance ratings of less than 3 hours. The DIBD20, 40, 60 carry a 1½ hour UL fire damper label and are classified as dynamic dampers for use in HVAC systems that remain in operation during a fire. The DIBD20, 40 and 60 are for dynamic closure to 2000 fpm and 4 inches w.g. static pressure. Ratings are for in duct and in wall/floor installations with horizontal airflow and vertical airflow, both up and down.

The DIBD20, 40, 60 are rated for dynamic closure to 2000 fpm and 4 inches w.g. static pressure.

STANDARD CONSTRUCTION

FRAME/SLEEVE

DIBD20 - 20 gage x 12" (1.0 x 305) galvanized, steel channel.

DIBD40 - 20 gage x 14" (1.0 x 356) galvanized, steel channel.

DIBD60 - 20 gage x 16" (1.0 x 406) galvanized, steel channel.

BLADES

24 gage (.7) galvanized curtain type in airstream.

CLOSURE SPRINGS (if required)

301 stainless steel constant force type.

FUSIBLE LINK

165°F (74°C) is standard. 212°F (100°C) and 285°F (141°C) available.

DAMPER SIZES

MINIMUM SIZE

Vertical Installation – 6"w x 4"h (152 x 102)

Horizontal Installation – 10"w x 8"h (254 x 203)

MAXIMUM SIZE

Vertical Installation – 33"w x 32"h (838 x 813)

Horizontal Installation – 36"w x 42"h (914 x 1067) or 48"w x 30"h (1219 x 762)

OPTIONS

- **Switch Package** to remotely indicate damper blade position.
- **FAST Angle** for one side angle installation
- **DIBD10** for easy all from one side installation.
- **G Style** for grille applications.
- **Access Door** factory mounted in common sleeve to ensure compliance with UL installation requirements.
- **FireStop Caulk Installation.**

NOTE

Dimensions shown in parentheses () indicate millimeters.

Models DIBD20, 40, 60 meet the requirements for fire, dampers established by:

- **National Fire Protection Association NFPA Standards 90A and 101**
- **BOCA National Building Codes**
- **ICBO Uniform Building Codes**
- **SBCCI Standard Building Codes**
- **ICC International Building Codes**
- **CSFM California State Fire Marshal Fire Damper Listing (#3225-245:005)**
- **New York City (BSA Listing #297-71-SA)**

UL CLASSIFIED

UL555 Listing R5531

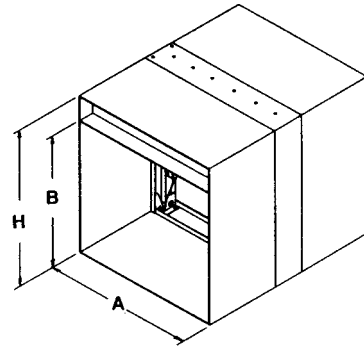

VERTICAL MOUNT

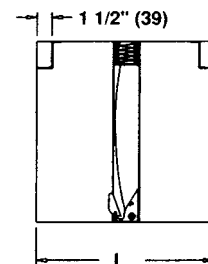

L = Frame/Sleeve Length

HORIZONTAL MOUNT

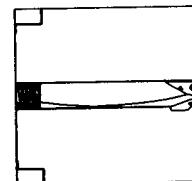

ASSEMBLY AND DIMENSIONAL INFORMATION

A and B dimensions are normally fabricated approximately 1/4" (6) less than given duct dimensions. A and B dimensions shown describe maximum UL Classified sizes. Ruskin recommends the authority having jurisdiction, the engineer and the contractor agree on the installation design prior to installation.

Multiple section dampers are shipped in individual sections, for field assembly.

If Ductmate or TDF breakaway connections are to be used, order dampers actual size.

VERTICAL INSTALLATION (Elevation View)

Single Section Dampers

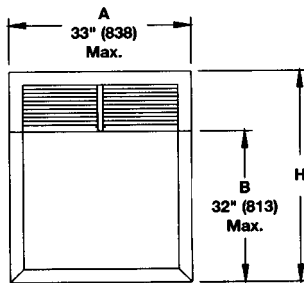

		Single Sections & Single High Assemblies	
B		H	
4	(102)	5 ³ / ₄	(146)
5	(127)	6 ³ / ₄	(171)
6	(152)	7 ³ / ₄	(197)
7	(178)	8 ³ / ₄	(222)
8	(203)	9 ³ / ₄	(248)
9	(229)	10 ³ / ₄	(273)
10	(254)	11 ³ / ₄	(298)
11	(279)	12 ³ / ₄	(324)
12	(305)	13 ³ / ₄	(349)
13	(330)	15 ³ / ₄	(400)
14	(356)	16 ³ / ₄	(425)
15	(381)	17 ³ / ₄	(451)
16	(406)	18 ³ / ₄	(476)
17	(432)	19 ³ / ₄	(502)
18	(457)	20 ³ / ₄	(527)
19	(483)	21 ³ / ₄	(552)
20	(508)	22 ³ / ₄	(578)
21	(533)	23 ³ / ₄	(603)
22	(559)	24 ³ / ₄	(629)
23	(584)	26 ³ / ₄	(679)
24	(610)	27 ³ / ₄	(705)
25	(635)	28 ³ / ₄	(730)
26	(660)	29 ³ / ₄	(756)
27	(686)	30 ³ / ₄	(781)
28	(711)	31 ³ / ₄	(806)
29	(737)	32 ³ / ₄	(832)
30	(762)	33 ³ / ₄	(857)
31	(787)	34 ³ / ₄	(883)
32	(813)	35 ³ / ₄	(908)

Dimensions shown in parentheses () indicate millimeters.

HORIZONTAL INSTALLATION (Elevation View)

Single Section Dampers

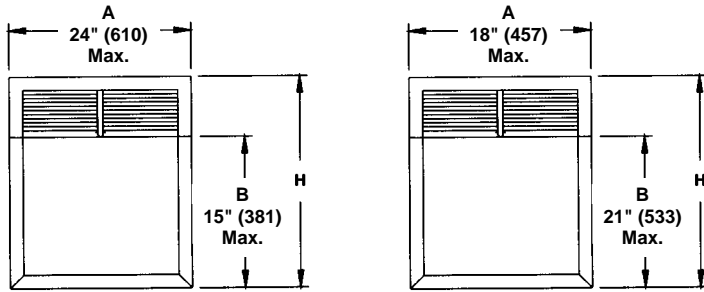

Multiple Section Dampers

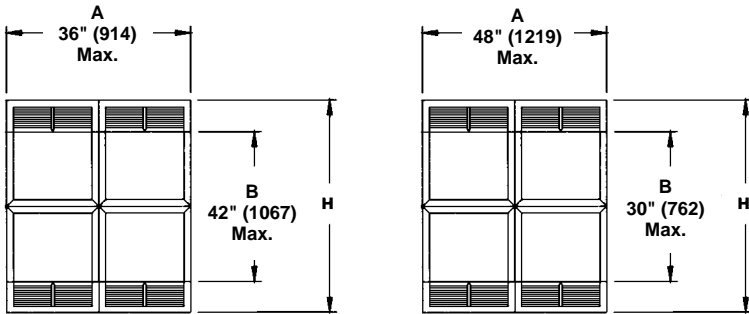

	Single Sections & Single High Assemblies	Double High Assemblies
B	H	H
8 (203)	9 ³ / ₄ (248)	
9 (229)	10 ³ / ₄ (273)	
10 (254)	11 ³ / ₄ (298)	
11 (279)	12 ³ / ₄ (324)	
12 (305)	13 ³ / ₄ (349)	
13 (330)	15 ³ / ₄ (400)	
14 (356)	16 ³ / ₄ (425)	
15 (381)	17 ³ / ₄ (451)	
16 (406)	18 ³ / ₄ (476)	
17 (432)	19 ³ / ₄ (502)	
18 (457)	20 ³ / ₄ (527)	
19 (483)	21 ³ / ₄ (552)	
20 (508)	22 ³ / ₄ (578)	
21 (533)	23 ³ / ₄ (603)	
22 (559)		25 ¹ / ₂ (648)
23 (584)		26 ¹ / ₂ (673)
24 (610)		27 ¹ / ₂ (699)
25 (635)		28 ¹ / ₂ (724)
26 (660)		31 ¹ / ₂ (800)
27 (686)		32 ¹ / ₂ (826)
28 (711)		33 ¹ / ₂ (851)
29 (737)		34 ¹ / ₂ (876)
30 (762)		35 ¹ / ₂ (902)
31 (787)		36 ¹ / ₂ (927)
32 (813)		37 ¹ / ₂ (953)
33 (838)		38 ¹ / ₂ (978)
34 (864)		39 ¹ / ₂ (1003)
35 (889)		40 ¹ / ₂ (1029)
36 (914)		41 ¹ / ₂ (1054)
37 (940)		42 ¹ / ₂ (1079)
38 (965)		43 ¹ / ₂ (1105)
39 (991)		44 ¹ / ₂ (1130)
40 (1016)		45 ¹ / ₂ (1156)
41 (1041)		46 ¹ / ₂ (1181)
42 (1067)		47 ¹ / ₂ (1206)

Dimensions shown in parentheses () indicate millimeters.

SUGGESTED SPECIFICATION

Furnish and install, at locations shown on the plans, dynamic fire dampers tested, constructed and labeled in accordance with the latest edition of UL Standard 555. Dampers shall have a fire rating of 1 1/2 hours and shall meet the requirements of the latest edition of NFPA90A.

Each damper shall include a 165°F (74°C) or 212°F (100°C) fusible link (*specifier select*) and shall be labeled for use in dynamic systems. Dampers labeled for use in static systems only are not permitted. The damper shall be rated for dynamic closure to a minimum 2000 fpm (610 meters per minute) and 4 inches w.g. (1 kPa) static pressure and shall be rated to close with air-flow in either direction.

Each dynamic fire damper shall include a 12", 14" or 16" (305, 356 or 406) (*specifier select*) long integral roll formed steel sleeve and mounting angles furnished by the damper manufacturer to ensure appropriate installation. Submittal information shall include the fire protection rating, maximum velocity/pressure ratings and the manufacturer's UL installation instructions. The dampers shall be installed in accordance with the manufacturer's UL installation instructions. Dynamic fire dampers shall be curtain type Ruskin model DIBD20 with 12" (305) sleeve, D"IBD40 with 14" (356) sleeve or DIBD60 with 16" (406) sleeve, Style A, B, CR, CO, R, LR or LO (*specifier select*).

LABOR SAVER ACCESSORY OPTIONS

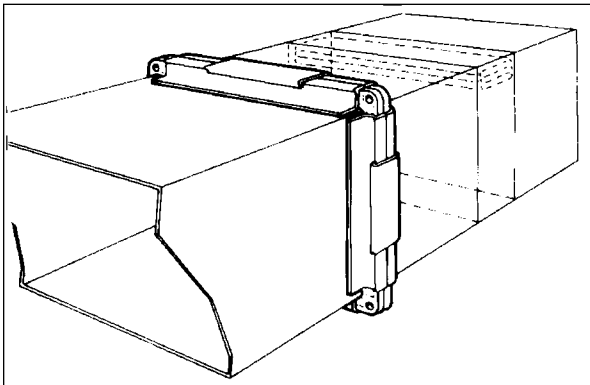

TDF OR DUCTMATE BREAKAWAY CONNECTIONS

Meet UL breakaway connection requirements without changing connectors. Use the same Ductmate or TDF connection between damper sleeve and ductwork as well as between pieces of ductwork.

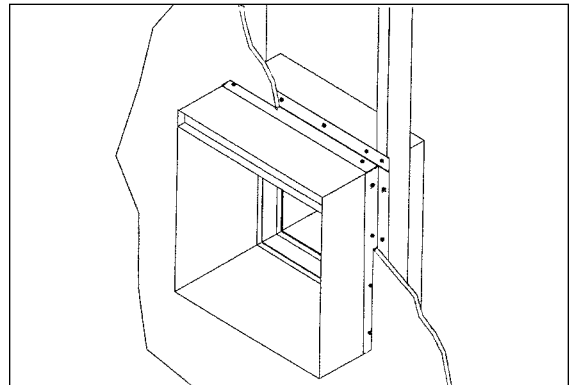

FAST MOUNTING ANGLE

FAST mounting angles are used in lieu of conventional, eight piece mounting angles and are installed on only **one side of the wall** when used with Ruskin fire dampers. The FAST angle can be fastened directly to the metal stud underneath the fire rated gypsum wallboard.

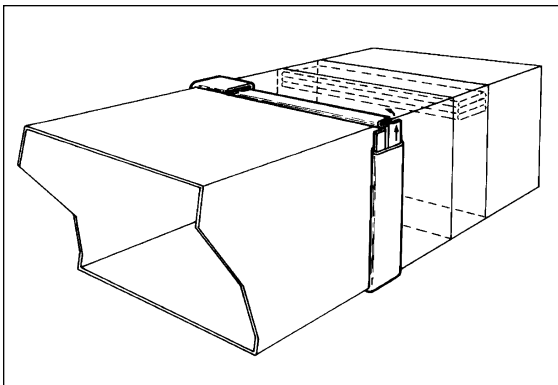

S-AND-DRIVEMATE BREAKAWAY CONNECTIONS

Use in lieu of S-Slip joints to join damper sleeve to ductwork for a strong connection that stays joined. Ruskin fire dampers with integral sleeves are available factory hemmed for S-and-Drivemate connections.

RUSKIN®

3900 Dr. Greaves Rd.
Kansas City, MO 64030
(816) 761-7476
FAX (816) 765-8955
www.ruskin.com